

# LEWA ecoflow

## Variable eccentric pump drive

### Type LDE

- Drive units
- Metering pumps

#### Performance

|                    |   |
|--------------------|---|
| <b>Pressure</b>    | up to 1000 bar                              |
| <b>Flow rate</b>   | up to 10 m <sup>3</sup> /h<br>per pump head |
| <b>Temperature</b> | up to 400°C                                 |



#### Customer advantages

- **Rod thrust:** 20 kN
- **Stroke length:** 30 mm
- **Stroke adjustment:** available with fixed stroke length or with stroke length adjustment. Setting of stroke length is carried out manually or electrically
- **Linear stroke adjustment** in steps of 0,01 mm via hand wheel while pump is stopped or in operation. Proven variable eccentric drive principle, that means stroke length is adjusted where it arises: at the eccentric
- **Multiplex drive units** also in different frame sizes with motor mounted horizontally. Common oil bath without radial shaft seal ring between the drive units (thus less wear parts)
- **Harmonic plunger motion** also at partial stroke
- **API 675 specification** is met
- **Differing stroke rates** make it possible to meet requirements for different fluids and process conditions
- **Long life** due to solid construction, best materials, oil bath lubrication, weather- and splash protection

#### Simple operation, easy maintenance

- **Pump head types:** plunger- and diaphragm pump heads can be mounted
- **Drive:** AC and DC motors, frequency inverter possible
- **Attachable instruments:** contactor

#### Method of operation

The drive shaft turns the **eccentric** via the **worm gear** and the **hollow shaft**. The **connecting rod** converts the rotary motion of the eccentric into a reciprocating motion of the **plunger rod**. The stroke length for the displacer movement is set (with the pump stopped or in operation) through radial shifting of the **eccentric**.

For this the **sliding shaft** is axially shifted via the **adjusting spindle**. The axial movement of the sliding shaft is converted into a radial movement of the **eccentric** via the skew-slotted groove in the **hollow shaft**.

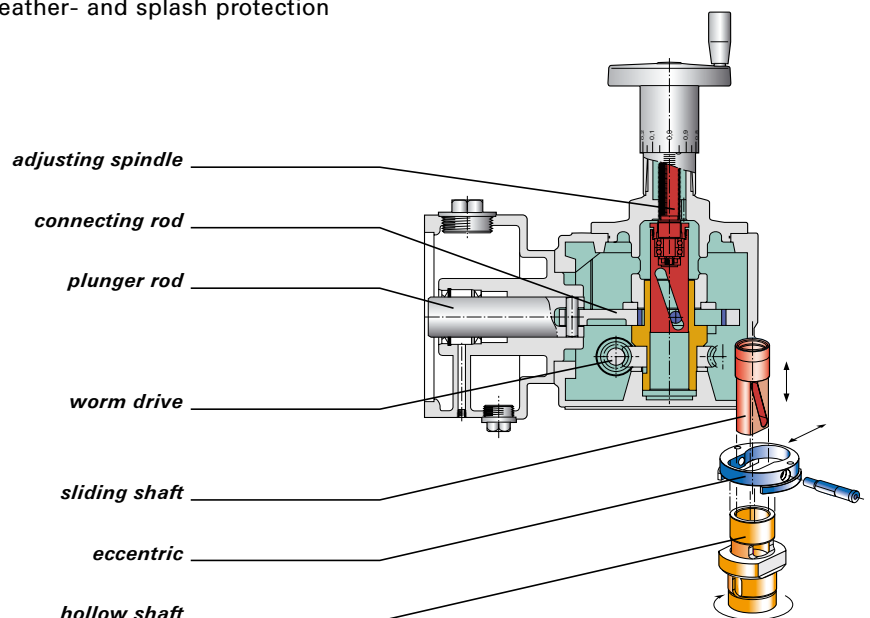

## Performance data

| Standard plunger<br>ø [mm] | Q <sub>theor.</sub> [l/h] <sup>1)</sup><br>Calc. flow rate per pump head at max. stroke length<br>and stroke frequency n [min <sup>-1</sup> ] |       |       |       |       | Permissible operating pressure of standard pump heads [barg] |       |                      |       |      |                    |  |
|----------------------------|---|-------|-------|-------|-------|--|-------|----------------------|-------|------|--------------------|--|
|                            |   |       |       |       |       | Type   |       | Diaphragm pump heads |       |      | Plunger pump heads |  |
|                            | 72  | 113   | 141   | 170   | 225   | Model <sup>3)</sup>  | M 900 | M 200                | M 500 | K    |                    |  |
|                            |   |       |       |       |       | Material <sup>2)</sup>                                       | 3     | 2, 3                 |       | 2, 3 |                    |  |
| 12                         | 14,66   | 23,00 | 28,70 | 34,61 | 45,80 |  | ---   | 1000                 | ---   | ---  |                    |  |
| 16                         | 26,06   | 40,90 | 51,03 | 61,52 | 81,43 |  | ---   | 700                  | ---   | 500  |                    |  |
| 17                         | 29,42   | 46,17 | 57,61 | 69,46 | 91,93 |  | 400   | ---                  | ---   | ---  |                    |  |
| 20                         | 40,72   | 63,90 | 79,73 | 96,13 | 127,2 |  | ---   | 500                  | ---   | 500  |                    |  |
| 21                         | 44,89   | 70,45 | 87,91 | 106,0 | 140,3 |  | 400   | ---                  | ---   | ---  |                    |  |
| 25                         | 63,62   | 99,84 | 124,6 | 150,2 | 198,8 |  | 350   | 407                  | ---   | 407  |                    |  |
| 30                         | 91,6  | 143,8 | 179,4 | 216,3 | 286,3 |  | 280   | 198                  | ---   | 283  |                    |  |
| 34                         | 117,7   | 184,7 | 230,4 | 277,8 | 367,7 |  | 218   | ---                  | ---   | ---  |                    |  |
| 36                         | 131,9   | 207,0 | 258,3 | 311,5 | 412,2 |  | ---   | 196                  | ---   | 196  |                    |  |
| 38                         | 147,0   | 230,7 | 287,8 | 347,0 | 459,3 |  | 174   | ---                  | ---   | ---  |                    |  |
| 42                         | 179,6   | 281,8 | 351,6 | 423,9 | 561,1 |  | 142   | ---                  | ---   | ---  |                    |  |
| 44                         | 197,1   | 309,3 | 385,9 | 465,3 | 615,8 |  | ---   | 107                  | ---   | 132  |                    |  |
| 46                         | 215,4   | 338,0 | 421,8 | 508,5 | 673,1 |  | 118   | ---                  | ---   | ---  |                    |  |
| 52                         | 275,2   | 432,0 | 539,0 | 649,9 | 860,1 |  | 91,7  | 94,2                 | ---   | 94,2 |                    |  |
| 58                         | 342,4   | 537,4 | 670,6 | 808,5 | 1070  |  | 73,2  | ---                  | ---   | ---  |                    |  |
| 60                         | 366,4   | 575,1 | 717,6 | 865,2 | 1145  |  | ---   | 50,0                 | ---   | 70,7 |                    |  |
| 66                         | 443,4   | 695,9 | 868,3 | 1047  | 1386  |  | 56,0  | ---                  | ---   | ---  |                    |  |
| 70                         | 498,8   | 782,8 | 976,7 | 1178  | 1559  |  | ---   | 50,0                 | ---   | 52,0 |                    |  |
| 74                         | 557,4   | 874,8 | 1092  | 1316  | 1742  |  | 44,0  | ---                  | ---   | ---  |                    |  |
| 82                         | 684,4   | 1074  | 1340  | 1616  | 2139  |  | 35,4  | ---                  | ---   | ---  |                    |  |
| 85                         | 735,4   | 1154  | 1440  | 1736  | 2298  |  | ---   | ---                  | ---   | 35,2 |                    |  |
| 92                         | 861,5   | 1352  | 1687  | 2034  | 2692  |  | 27,6  | ---                  | ---   | ---  |                    |  |
| 100                        | 1018  | 1598  | 1993  | 2403  | 3181  |  | ---   | ---                  | ---   | 25,5 |                    |  |
| 104                        | 1101  | 1728  | 2156  | 2599  | 3440  |  | 21,0  | ---                  | ---   | ---  |                    |  |
| 116                        | 1370  | 2150  | 2682  | 3234  | 4280  |  | 16,4  | ---                  | ---   | ---  |                    |  |
| 120                        | 1466  | 2300  | 2870  | 3461  | 4580  |  | ---   | ---                  | 17,7  | 17,7 |                    |  |
| 140                        | 1995  | 3131  | 3907  | 4711  | 6234  |  | ---   | ---                  | 13,0  | 13,0 |                    |  |
| 175                        | 3117  | 4892  | 6105  | 7360  | 9741  |  | ---   | ---                  | 8,3   | 8,3  |                    |  |

1) Q<sub>theor.</sub> from stroke volume x stroke frequency. Q<sub>eff.</sub> (= Q<sub>theor.</sub> x η<sub>p</sub>) is stated in technical data sheet. For multiplex pumps, determine total metered flow by multiplying by the number of pump heads

2) 2 = 13 % Cr steel; 3 = stainless steel CrNiMo 18/10/2; other materials, e.g. Hastelloy to special order

3) Standard pump head connections depending on pump head size: internal thread to DIN or NPT resp. flanges to DIN or ANSI

## Dimensions

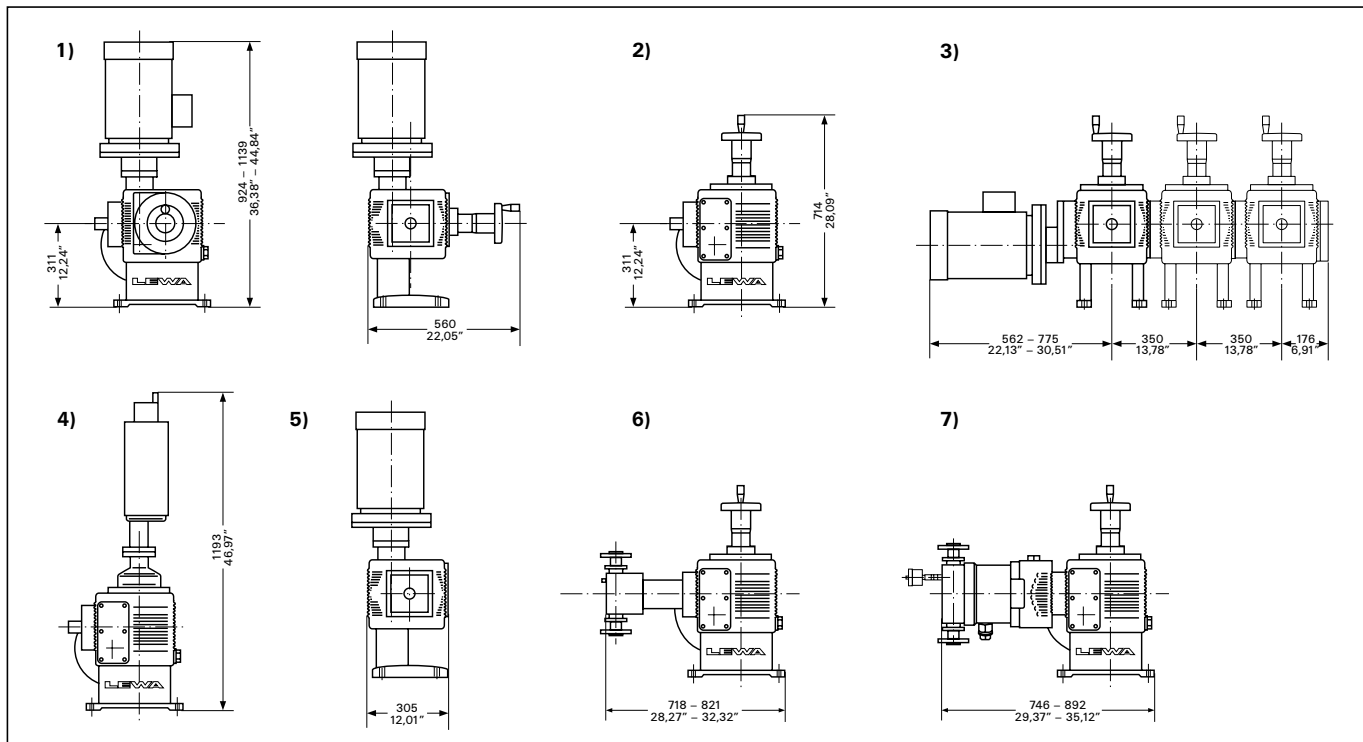

### Drive units

- 1) Simplex drive unit with manual stroke adjustment / motor mounted vertically
- 2) Simplex drive unit with manual stroke adjustment / motor mounted horizontally
- 3) Multiplex drive unit with manual stroke adjustment / motor mounted horizontally
- 4) Simplex drive unit with electric stroke adjustment / motor mounted horizontally
- 5) Simplex drive unit without stroke adjustment / motor mounted vertically

### Pumps

- 6) Plunger pump
- 7) Diaphragm pump

**LEWA**  
pumps + systems

LEWA GmbH

Ulmer Str. 10  
71229 Leonberg  
Phone +49 7152 14-0  
Fax +49 7152 14-1303  
lewa@lewa.de  
www.lewa.de